

MASTER[®]

Model #: MH-125-OFR



CONSUMER: Retain this manual for future reference.

IMPORTANT: Read and understand all of the directions in this manual before assembling, starting, or servicing the heater. Improper use of this heater can cause serious injury. Keep this manual for future reference.

▲ DANGER GENERAL HAZARD WARNING:

Be sure to comply with the instructions and warnings provided with this heater, or death, serious bodily injury and property loss, damage from the hazards of fire, explosion, burn, asphyxiation, and carbon monoxide poisoning can result. Only persons who can follow and understand these instructions should use or service this heater. If you need heater information such as an instruction manual, labels, etcetera, contact the manufacturer.

▲ DANGER Not for use in residential living areas or in non-adequately ventilated enclosed spaces.

Pinnacle Products International, Inc. 668 Stony Hill Road #302 Yardley, PA 19067 USA
Phone: 215-891-8460 Fax: 215-891-8461 Web: www.pinnacleint.com Email: info@pinnacleint.com

**NEVER LEAVE HEATER
UNATTENDED WHILE BURN-
ING OR WHILE CONNECTED
TO A POWER SOURCE**

MASTER®

Oil-Fired Radiant Heaters

Table of Contents

Warnings.....	2
Safety Information.....	2-3
Specifications.....	3
Features.....	4
Theory of Operation.....	5
Assembly.....	5
Fuels.....	5
Ventilation.....	5
Operation.....	6
Maintenance.....	6-7
Storage.....	7
Exploded Parts Drawing.....	8
Replacement Part Listing.....	9
Wiring Diagrams.....	10
Troubleshooting.....	11
Warranty.....	Back Page

Safety Information

▲ DANGER Carbon Monoxide poisoning may lead to death!

This is a kerosene, direct-fired, radiant heater. It is primarily intended for use for temporary heating of buildings under construction, alteration or repair. Direct-fired means that all of the combustion products of the heater enter the heated space. This appliance is rated at 98% combustion efficiency, but does produce small amounts of carbon monoxide. Carbon monoxide is toxic. Humans can tolerate small amounts of carbon monoxide, and precautions should be taken to provide proper ventilation. People with breathing problems should consult a physician before using the heater. Failure to provide proper ventilation in according to this manual can result in death. Early signs of carbon monoxide poisoning resemble the flu. Symptoms of improper ventilation are:

- * headache * dizziness * burning of the nose and eyes
- * nausea * dry mouth * sore throat *

If the heater is being used in the presence of others, be sure to inform them of all proper safety precautions, operating procedures and hazards. **Some people are more affected by carbon monoxide than others.** These are pregnant women, people with heart or lung disease or anemia, those under the influence of alcohol or at high altitudes. For optimal performance of this heater, it is strongly suggested that 1-K kerosene be used. 1-K kerosene has been refined to virtually eliminate contaminants, such as sulfur, which can cause a rotten egg odor during the operation of the heater. However, #1 or #2 fuel oil (diesel fuel) may also be used if 1-K kerosene is not available. Be advised that these fuels do not burn as clean as 1-K kerosene, and care should be taken to provide more fresh air ventilation to accommodate any added contaminants that may be added to the heated space. Use of #1 or #2 fuel oil may result in more periodic maintenance.

- Check the heater thoroughly for damage before each use. DO NOT operate a damaged heater.
- DO NOT modify this heater or operate a heater that has been modified from it's original state.

▲ WARNING Risk of indoor air pollution!

- **Suitable for outdoor use.** Use this heater only in well ventilated areas! Provide at least 3 square feet (2,800 sq cm) of opening per 100,000 Btu of rated operation (See page 5).
- Never use heater in occupied dwellings.
- Keep heater area free from combustible materials such as gasoline, paint thinners and other flammable vapors and liquids. Dust is combustible. Do not use heater in areas of high dust concentration.
- Never use this heater in living or sleeping areas.

▲ WARNING Fire, burn, inhalation, and explosion hazard. Keep combustibles, such as building materials, paper or cardboard, a safe distance away from the heater as recommended by these instructions. Never use the heater in spaces which contain products such as gasoline, solvents, paint thinners, dust particles, volatile or airborne combustibles, or any unknown chemicals.

▲ WARNING This is an unvented portable heater. It uses air (oxygen) from the area in which it is used. Adequate combustion and ventilation air must be provided. Refer to VENTILATION Page 5.

▲ WARNING Do not operate this heater until you have read, and thoroughly understand these safety and operating instructions. Failure to comply with the precautions and instructions provided with this heater can result in death, serious bodily injury, property loss or damage from the hazards of fire, soot production, explosion, burns, asphyxiation or carbon monoxide poisoning. Only persons who can read and understand these instructions should use or service this heater. Not for use in homes or recreational vehicles.

California Residents: Combustion by-products produced when using this product contain carbon monoxide, a chemical known to the state of California to cause cancer and birth defects (or other reproductive harm).

Massachusetts Residents: Massachusetts state law prohibits the use of this heater in any building which is used in whole or in part for human habitation. Use of this heating device in Massachusetts requires local fire department permit (M.G.L.C. 148, Section 10A).

Minimum clearance from Combustibles:

	Top	Sides	Front
125k	6 ft.	6 ft.	6 ft.

**NEVER LEAVE HEATER
UNATTENDED WHILE BURN-
ING OR WHILE CONNECTED
TO A POWER SOURCE**

MASTER

**Oil-Fired Radiant
Heaters**

Safety Information (Continued)

- Operate only on level and stable surfaces.
- Do not restrict inlet (rear) or outlet (front) of heater. Heater is never to be used with ductwork.
- Operate heater in a manner that will not directly expose it to water, water spray, rain, wind or dripping water.
- NEVER leave heater unattended.
- ALWAYS keep children and animals away from heater.
- To prevent injury, always wear gloves when handling heater. Never handle an operating or hot heater, as severe burns may result.
- **Risk of burns / fire / explosion!** NEVER use gasoline, naphtha, benzene, paint thinner, alcohol or other fuels of any kind to operate this heater.
- This heater is not for use on finished floors. Use a heat shielding mat on a heat sensitive floor.
- Use heater in accordance to local codes and Federal Ordinances.
- **Risk of electric shock!** Use only the electrical/power cord specified. Electrical and grounding connection must comply with National Electrical Code - ANSI/NFPA 70 (USA) and CSA C22.1 Canadian Electrical Code, Part 1 (Canada).
- Never move or handle heater while still hot.
- Never transport heater with fuel in its tank.
- NEVER refill the heater's fuel tank while heater is operating or still hot. This heater is EXTREMELY HOT while in operation.
- Bulk fuel storage should be a minimum of 25 ft. from heaters, torches, portable generators, or other sources of ignition. All fuel storage should be in accordance with federal, state, or local authorities having jurisdiction.
- Use only the electrical power (voltage and frequency) specified on the model plate of the heater. Use only a three-prong, grounded outlet and extension cord.
- ALWAYS unplug the heater when not in use.

Specifications

Model #	MH-125-OFR
Rating BTU/Hr	125,000 / 95,000
Volts / Hz / Amps	AC 120 / 60 / 5
Fuel Consumption (Gal/Hr)	.9
Fuel Tank Capacity (Gallons)	16
Max Operating Hours	16.5
Heat Type	Radiant
Heating Area (Sq Ft)	3,125
Overheat Shut-Off System	Yes
Size (L x W x H)	28.9" x 27.8" x 38.6"
Weight (Lbs)	84

Figure 1. Model Specifications

Model No.	Length	Width	Height
MH-125-OFR	28.9"	27.8"	38.6"

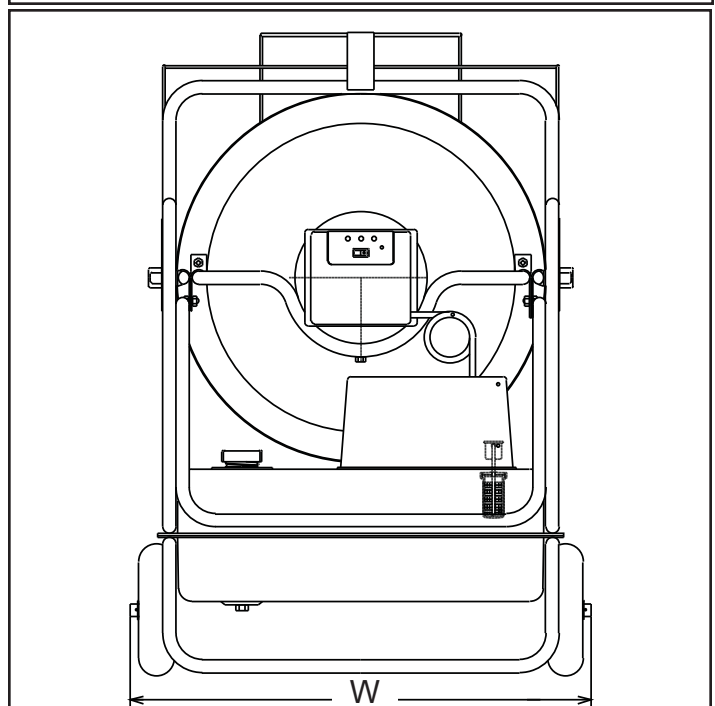
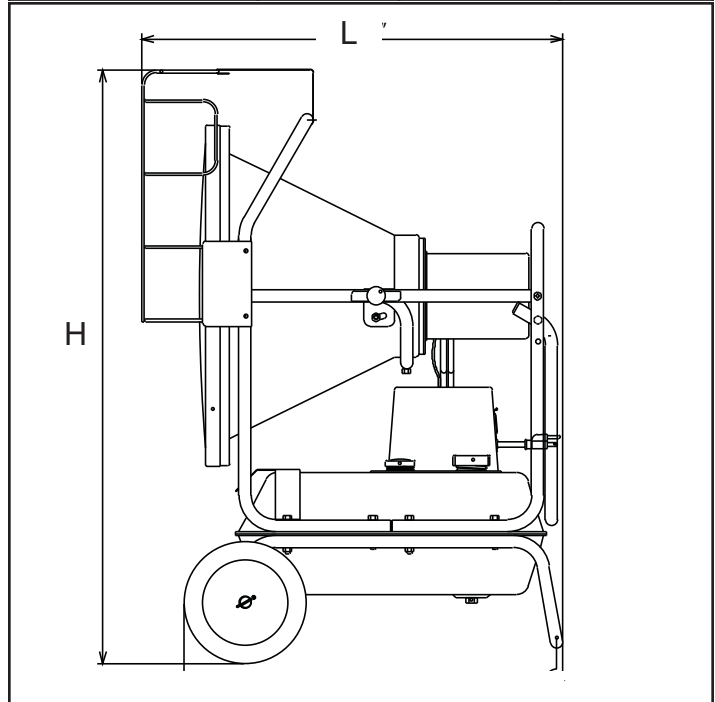

Figure 2. Product Dimensions

Specifications subject to change without notice

NEVER LEAVE HEATER
UNATTENDED WHILE BURN-
ING OR WHILE CONNECTED
TO A POWER SOURCE

MASTER®

Oil-Fired Radiant Heaters

Features

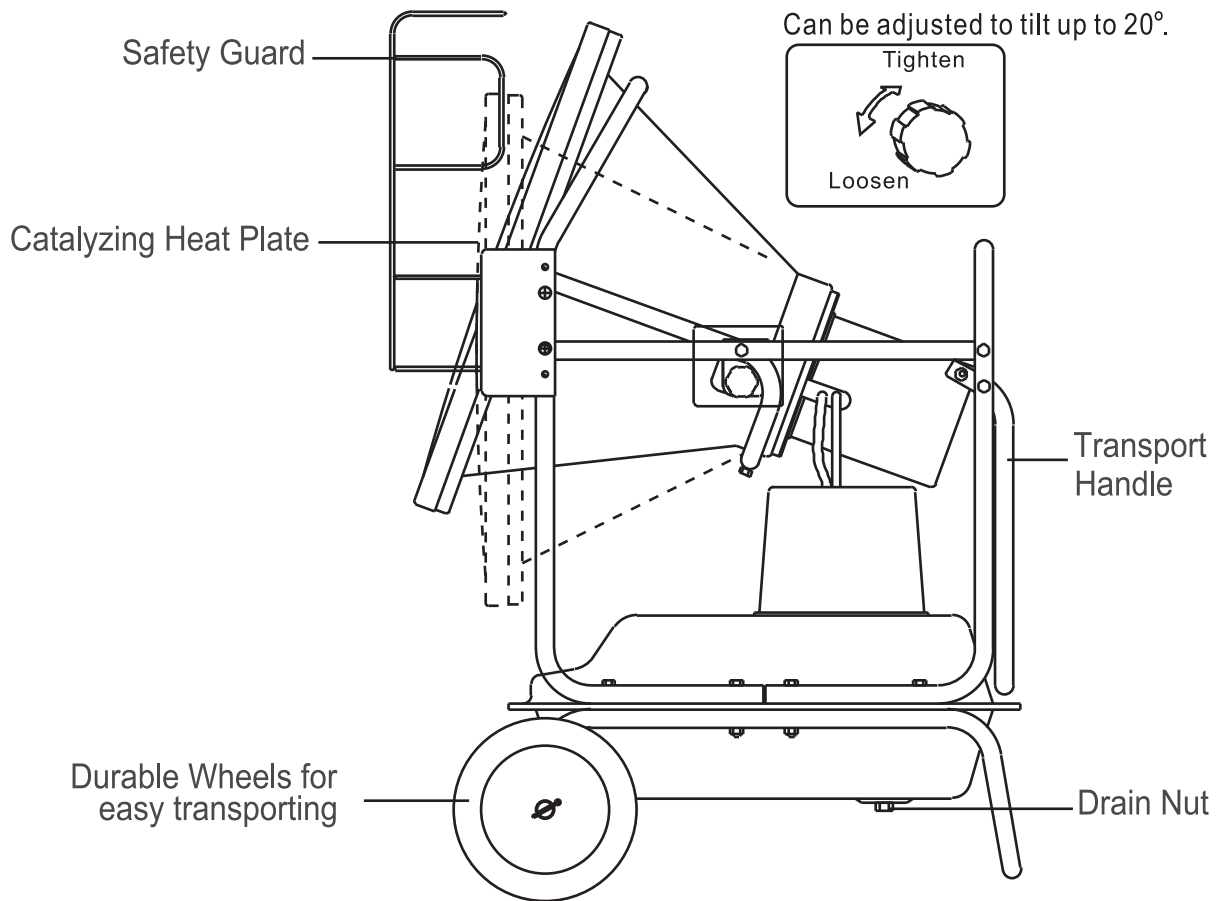

Figure 3. Product Features

Theory of Operation

Fuel System: This heater is equipped with a high-pressure pump. The pump draws fuel up from the fuel tank to the nozzle in the burner head. It is sprayed into the combustion chamber in a fine mist where it is mixed with air for combustion.

Quick-Fire Ignition: A transformer sends high voltage to a two-pronged spark plug. The spark ignites the fuel/air mixture as it is sprayed into the combustion chamber.

Air System: A blower motor assembly forces air around the combustion chamber, where it is super-heated and forced out the front of the chamber. A cooling fan blows air up and around the chamber during operation and also runs during the cool-down period.

Electrical System Protection: The heater's electrical system is protected by a circuit breaker that protects the system components from damage. If the heater fails, check the fuse first, and replace if necessary (see page 10).

Flame Sensor: The heater uses a photocell to see the flame in the combustion chamber. Should the flame extinguish, the sensor will stop electrical current and the heater will shut off.

Tipover Sensor: The heater uses a tipover sensor.

NEVER LEAVE HEATER UNATTENDED WHILE BURNING OR WHILE CONNECTED TO A POWER SOURCE

MASTER®

Oil-Fired Radiant Heaters

Assembly

1. Slide axle through Wheel Frame and attach wheels, washers and cotter pins.

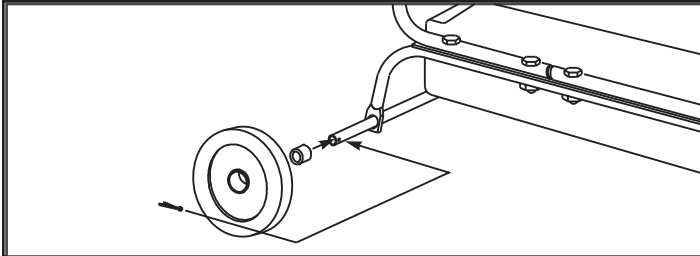

Figure 4a.

2. Place main structure on Wheel Frame and fasten with screws provided (Screws used for temporary joint in packing are not needed for assembly).

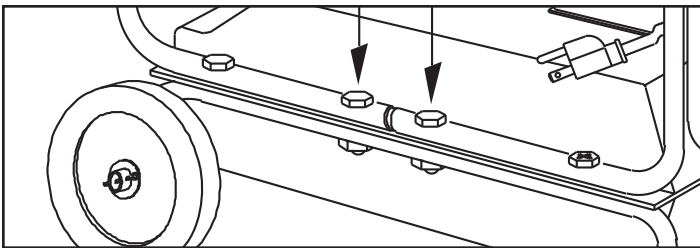

Figure 4b.

3. Attach Safety Guard to front of heater with screws provided.

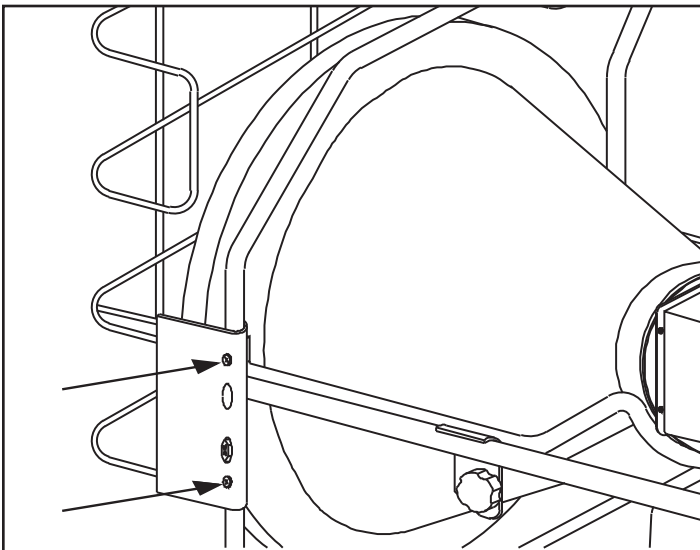

Figure 4c.

NOTE: Save the box and packaging materials for future storage.

▲WARNING *Never use fuels such as gasoline, benzine, alcohol, white gas, camp stove fuel, paint thinners or other oil products to fuel this heater. These are volatile fuels that could cause an explosion or uncontrolled flame.*

Fuel (1-K Kerosene)

For optimal performance of this heater, it is strongly suggested that 1-K kerosene be used. 1-K kerosene has been refined to virtually eliminate contaminants, such as sulfur, which can cause a rotten egg odor during the operation of the heater. However, #1 or #2 fuel oil (diesel fuel) may also be used if 1-K kerosene is not available. Be advised that these fuels do not burn as clean as 1-K kerosene, and care should be taken to provide more fresh air ventilation to accommodate any added contaminants that may be added to the heated space. Using diesel fuel can cause excess soot production. DO NOT use any fuel that is not approved above.

Kerosene should only be stored in a blue container that is clearly marked “kerosene”. Never store kerosene in a red container, because red containers are associated with gasoline.

Never store kerosene in a living area. Kerosene should always be stored in a well ventilated area outside of the living space.

Never store kerosene in direct sunlight or near any heating source.

Never use kerosene that has been stored from one season to the next. Kerosene and diesel fuel break down over time.

Old fuel will not burn properly in this heater. Use of old or contaminated kerosene can lead to excessive soot production.

Fueling the Heater

▲WARNING **Never fill the fuel tank indoors. Always fill the tank outdoors. Be sure that the heater is on level ground when fueling, and never overfill the fuel tank.**

It is always a good idea to fire the heater outdoors for the first time. This will allow any oils used in the manufacturing process to be burned off in a safe environment. This initial burn should last at least 10 minutes.

▲WARNING **Never refuel this heater while it is hot or operating. Fire or explosion could result.**

Ventilation

Always provide a fresh air opening in the heated space of at least three square feet (2,800 sq. cm) for the MH-125-OFR. Provide a larger opening if more heaters are being used. As an example, a MH-125-OFR (125,000 BTU/hr) heater will require:

- a two-car garage door open 4 inches, or
- a single car garage open 6 inches, or
- two windows (30" wide each) open 8 inches.

**NEVER LEAVE HEATER
UNATTENDED WHILE BURN-
ING OR WHILE CONNECTED
TO A POWER SOURCE**

MASTER®

Oil-Fired Radiant Heaters

Operation

To Start the Heater

1. Fill the tank with approved fuel until fuel gauge points to "F".
2. Be sure fuel cap is secure.
3. Plug power cord into three prong, grounded extension cord and plug extension cord into three prong 120V grounded outlet. The extension cord should be at least six feet long.

Extension cord wire size requirements are as follows:

- 6 to 10 feet (1.8 to 3 meters), use 18 AWG wire.
 - 11 to 100 feet (3.4 to 30.4 meters), use 16 AWG wire.
 - 101 to 200 feet (30.8 to 61 meters), use 14 AWG wire.
4. Push the Operation switch to the "LOW" or "HIGH" position. The power indicator lamp will light and the heater will start. When switching from one heat level to another during operation it is normal for the heater to cease operations and go into the misfire sequence. If this condition happens, simply switch to OFF and immediately switch to the heat level desired..

NOTE: The electrical components of this heater are protected by a fuse mounted in the PC board. If the heater fails to fire, check this fuse first, and replace if necessary. Also check the power source to be sure that the proper voltage is being provided to the heater.

▲ WARNING *Do not disconnect the power source or unplug the power cord until the cooling cycle has been completed!*

To Stop the Heater

1. Push the Operation switch to "OFF" position. Combustion will stop, and the Cooling Cycle (approx. 3 minutes in duration) will begin.
2. When Cooling Cycle is completed (fan stops running), it is safe to unplug the heater.

Unplugging the heater before the Cooling Cycle has ended may cause overheating, possible damage the heater and heat plate, and **will** void the warranty.

To Restart the Heater

1. Wait ten seconds after cooling cycle has completed.
2. Push the Operation switch to the "LOW" or "HIGH" position.
3. Be sure to follow all starting procedure precautions.

Maintenance

NEVER OPERATE THIS HEATER UNATTENDED!

▲ WARNING *Never service heater while hot or still connected to electrical source.*

Use only original equipment replacement parts. The use of alternate or third party components can cause unsafe operating conditions, and will void your warranty.

We suggest following a maintenance schedule as follows:

Fuel/Fuel Tank - Flush every 200 hours of operation or as needed. Do not use water to flush the tank. Use fresh 1-K kerosene only.

Filter - The Fuel Filter should be cleaned at least twice per heating season by rinsing it in clean 1-K kerosene. Contaminated fuel could make this necessary immediately (see **Figure 5**).

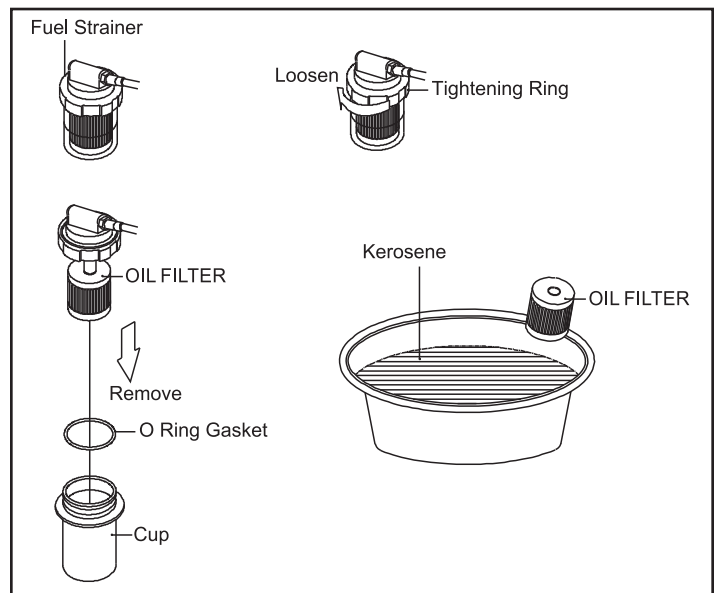

Figure 5. Filter Maintenance

**NEVER LEAVE HEATER
UNATTENDED WHILE BURN-
ING OR WHILE CONNECTED
TO A POWER SOURCE**

MASTER®

Oil-Fired Radiant Heaters

Maintenance (Continued)

Nozzle - Nozzles should be cleaned or replaced at least once per heating season. Contaminated fuel could make this necessary immediately.

- To clean dirt from nozzle, blow compressed air through nozzle front. It may be necessary to soak nozzle in clean 1-K kerosene to help loosen any particles (**Figure 6**).

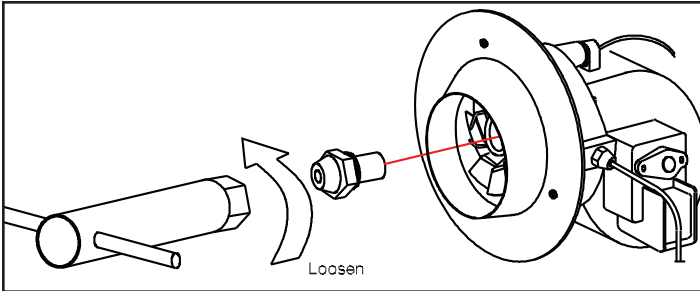

Figure 6. Nozzle Removal

Spark Plug - Clean and re-gap every 600 hours of operation, or replace as needed.

- After removing the Spark Plug, clean the terminals with a wire brush.

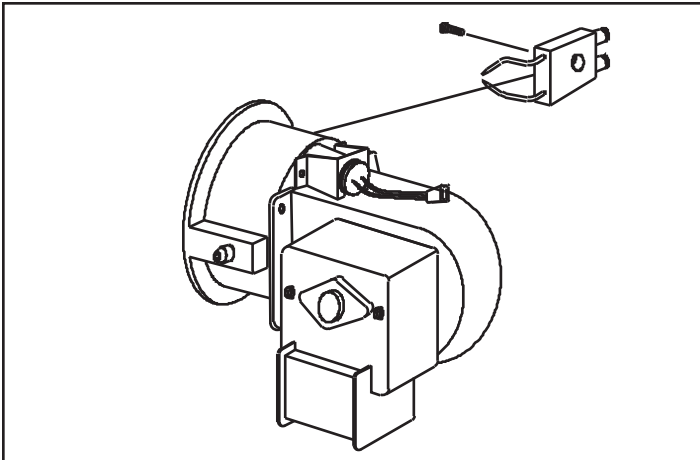

Figure 7. Spark Plug Location

Photocell - The Photocell should be cleaned at least once per heating season or more depending on conditions.

Use a cotton swab dipped in water or alcohol to clean the lens of the Photocell (**Figures 8 and 9**).

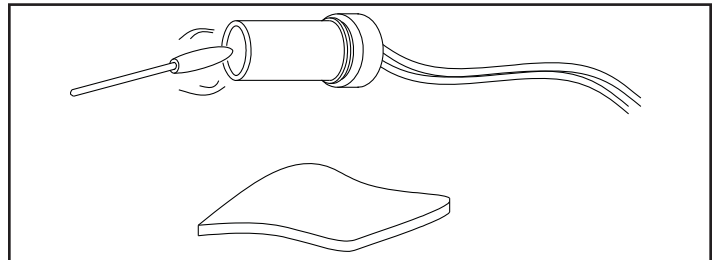

Figure 8. Photocell Maintenance

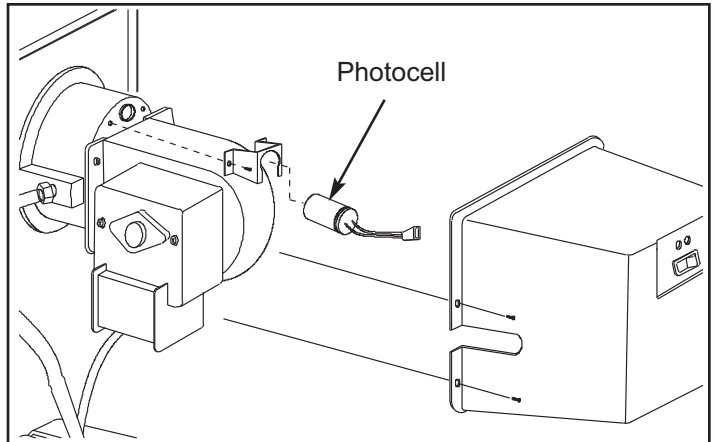

Figure 9. Photocell Location

Long Term Storage

- Unscrew the Drain Bolt and drain fuel.
- Using a small amount of kerosene, rinse and swirl the kerosene inside of the Fuel Tank. Empty the tank completely.
- NEVER MIX WATER WITH KEROSENE, as it will cause rust inside the tank.

Never store leftover kerosene over the summer. Using old fuel can damage your heater.

Store heater in a dry, well-ventilated area

- Be sure that the storage area is free of dust and corrosive vapors. Repack the heater in the original shipping material. Keep this User's Manual in an easily accessible place.

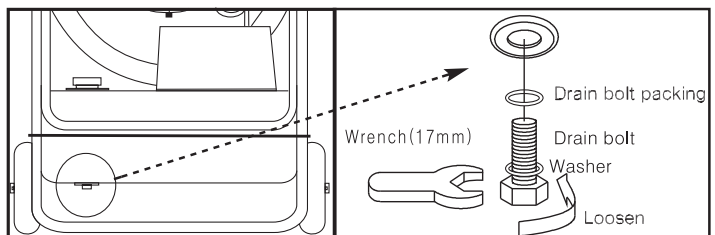

Figure 10. Drain Bolt

NEVER LEAVE HEATER
UNATTENDED WHILE BURN-
ING OR WHILE CONNECTED
TO A POWER SOURCE

MASTER®

Oil-Fired Radiant Heaters

Exploded Drawing Part Breakdown

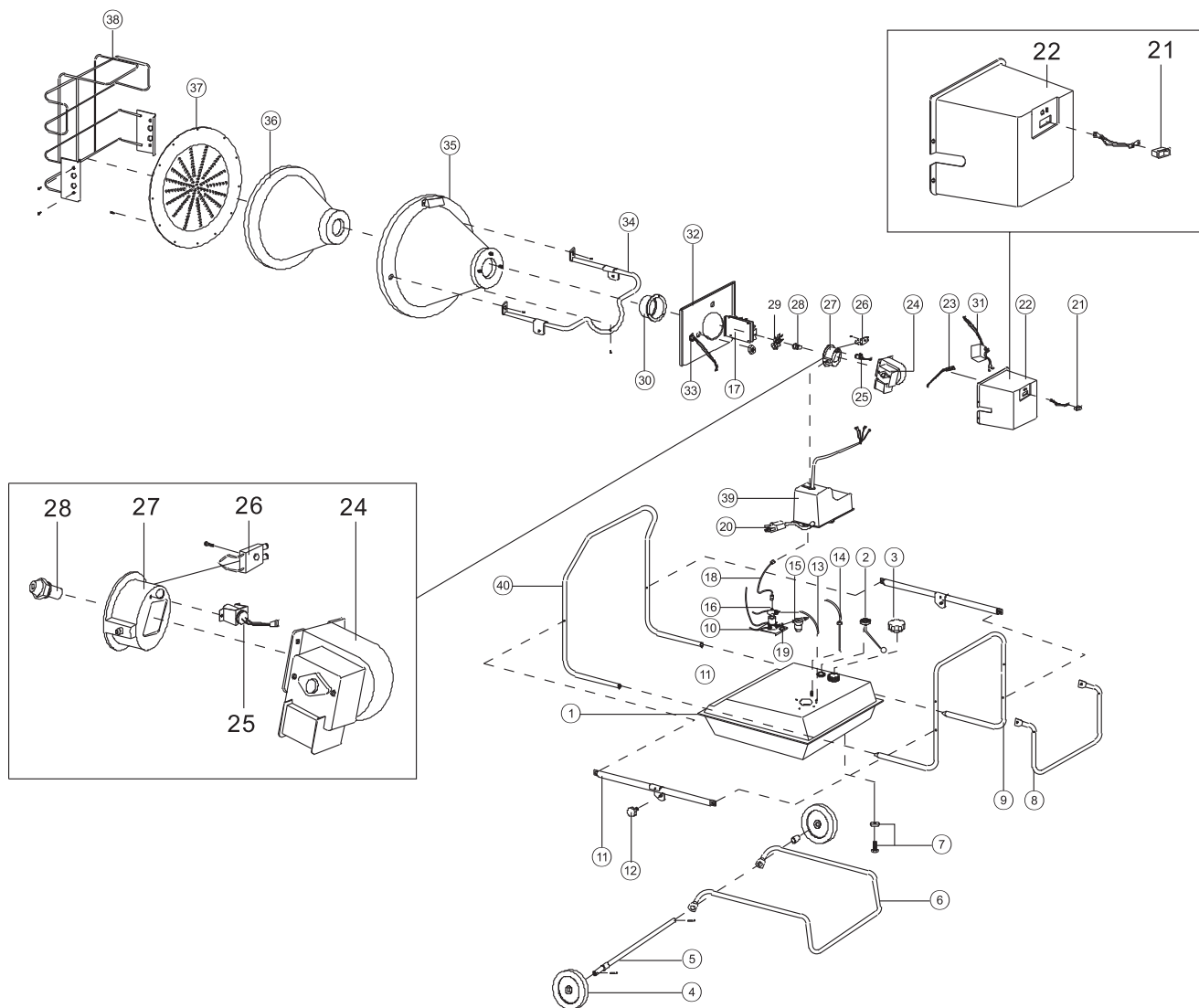

Figure 11. Exploded View: MH-125-OFR

Replacement Parts

Item #	Description	PT-125-OFR
1	Fuel Tank Assembly	72-001-0100
2	Fuel Gauge Assembly	72-022-0100
3	Fuel Tank Cap Assembly	75-002-0100
4	Wheel	72-041-0100
5	Axle	72-041-0200
6	Wheel Frame	72-042-0100

**NEVER LEAVE HEATER
UNATTENDED WHILE BURN-
ING OR WHILE CONNECTED
TO A POWER SOURCE**

MASTER®

**Oil-Fired Radiant
Heaters**

Replacement Parts

Item #	Description	PT-125-OFR
7	Drain Bolt	72-002-0200
8	Transport Handle	72-042-0200
9	Rear Frame	72-042-0300
10	Pump Support Plate	72-025-0500
11	Frame Support	72-035-0300
12	Height Adjustment Knob	72-042-0500
13	Return Fuel Line	72-023-0100
14	Intake Fuel Line	72-023-0200
15	Fuel Filter Assembly	72-020-0100
16	Fuel Pump Assembly	72-027-0100
17	Main PCB and Fuse	75-025-0400
18	Intake Fuel Hose	72-023-0300
19	Tip Over Sensor	75-051-0200
20	Power Cord	75-032-0150
21	Operation Switch	72-012-0100
22	Back Cover	72-013-0100
23	Panel sub-PCB	72-014-0100
24	Blower Motor Assembly	72-045-0100
25	Photocell Assembly	75-038-0200
26	Spark Plug	75-075-0200
27	Burner Body	72-035-0200
28	Nozzle	72-036-0100
29	Burner Blade	72-035-0500
30	Diffusion Cap	72-036-0200
31	Ignitor	75-025-0120
32	Burner Support Plate	72-035-0100
33	Temperature Overheat Sensor	72-040-0100
34	Radiant Cone Support Assembly	72-035-0600
35	Radiant Cone Assembly	72-035-0610
36	Ceramic Fiber	72-035-0620
37	Heat Plate	72-012-0400
38	Safety Guard	72-012-0200
39	Control Box	72-033-0100
40	Front Frame	72-042-0400

NEVER LEAVE HEATER
UNATTENDED WHILE BURN-
ING OR WHILE CONNECTED
TO A POWER SOURCE

MASTER®

Oil-Fired Radiant Heaters

Wiring Diagrams

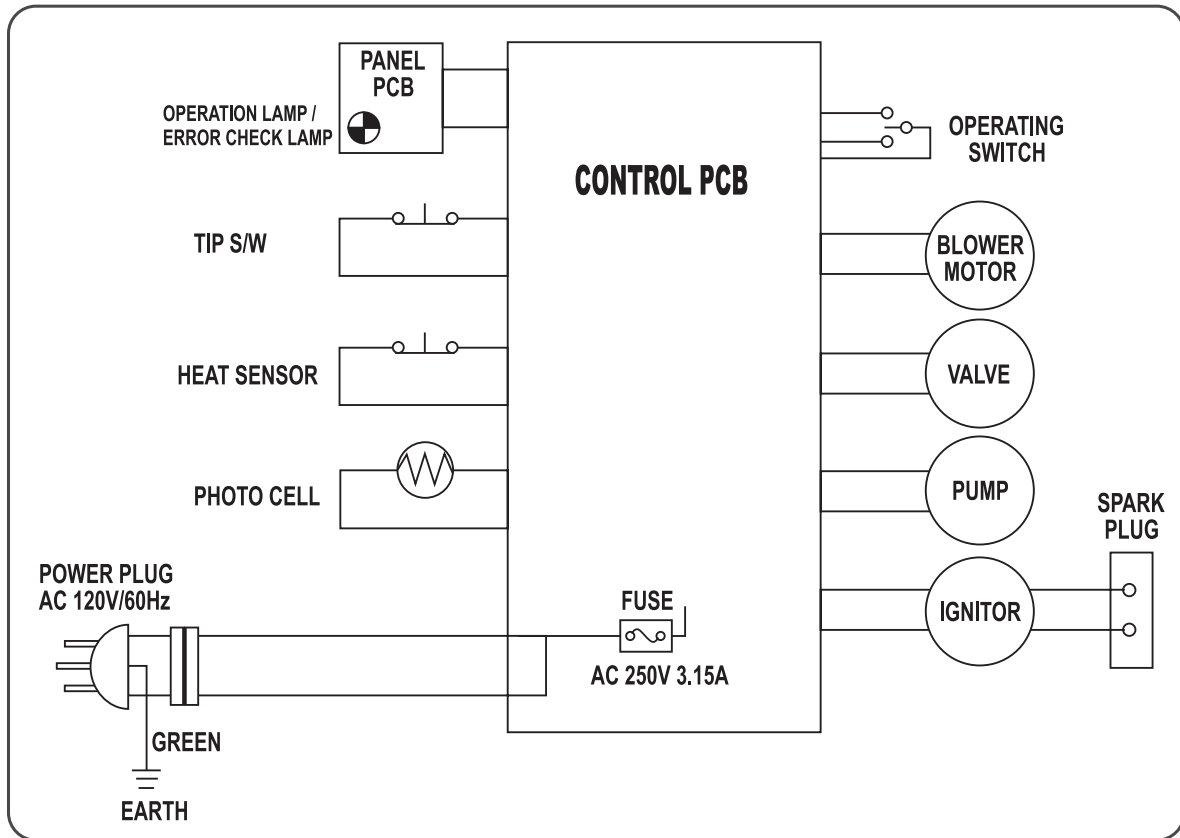

Figure 12. Wiring Diagram for model MH-125-OFR
(subject to change without notice)

Trouble Shooting Guide

Problem	Possible Cause	Solution
Heater fires, but shuts down after a short period of time.	<ol style="list-style-type: none"> 1. Dirty Fuel Filter. 2. Nozzle Dirty. 3. Photocell Dirty. 4. Photocell not installed properly. 5. Photocell Defective . 6. Improper electrical connection between Circuit Board and Photocell. 7. Cooling Fan is obstructed 	<ol style="list-style-type: none"> 1. Clean/replace Fuel Filter (Page 6). 2. Clean/replace Nozzle (Page 7). 3. Clean/replace Photocell (Page 7). 4. Adjust Photocell position. 5. Replace Photocell. 6. Check wiring connections (See Wiring Diagrams, Page 10). 7. Check to be sure cooling fan is not obstructed.
Heater will not operate, or motor runs for short time.	<ol style="list-style-type: none"> 1. No fuel in fuel tank. 2. Corroded Spark Plug or incorrect plug gap. 3. Dirty Fuel Filter. 4. Dirty Nozzle. 5. Moisture in Fuel/Fuel Tank. 6. Improper electrical connection between Transformer and Circuit Board. 7. Transformer Wires not connected to Spark Plug. 8. Defective Transformer. 	<ol style="list-style-type: none"> 1. Fill tank with fresh fuel. 2. Clean/replace Spark Plug (Page 7). 3. Clean/replace Fuel Filter (Page 6). 4. Clean/replace Nozzle (Page 7). 5. Rinse out fuel tank with clean fresh fuel (Page 7). 6. Inspect all electrical connections. (See Wiring Diagrams, Page 10). 7. Re-attach Transformer wires to Spark Plug. 8. Replace Transformer.
Fan does not operate when heater is plugged in and Power Switch is in the "ON" position.	<ol style="list-style-type: none"> 1. Broken electrical connection between Circuit Board and motor. 2. Not enough amps available to power heater. 	<ol style="list-style-type: none"> 1. Inspect all electrical connections on Wiring Diagrams (Page 10). 2. Use a new extension cord or try another electrical socket.
Heater does not turn on and the lamp is not lit.	<ol style="list-style-type: none"> 1. Temperature limit sensor has over-heated. 2. No electrical power. 3. Fuse break down. 4. Improper electrical connection between Temperature Limit Sensor and Circuit Board. 	<ol style="list-style-type: none"> 1. Push Power Switch to "OFF" and allow heater to cool for 5 minutes. Push Power Switch to back to "LOW" or "HIGH". 2. Check power cord and extension cord to insure of proper connection. Test power supply. 3. Check/replace Fuse. 4. Inspect all electrical connections. (See Wiring Diagrams, Page 10).
Poor combustion and / or soot production.	<ol style="list-style-type: none"> 1. Pump Pressure. 2. Poor fuel quality. 	<ol style="list-style-type: none"> 1. Be sure pump pressure is adjusted correctly. 2. Be sure fuel is not old or contaminated.

NEVER LEAVE HEATER
UNATTENDED WHILE BURN-
ING OR WHILE CONNECTED
TO A POWER SOURCE

MASTER[®]

Oil-Fired Radiant
Heaters

LIMITED WARRANTY

Pinnacle Products International, Inc. warrants this heater to the original retail purchaser only, to be free from defects in material and workmanship for a period of one (1) year from the date of initial purchase. This product must be properly installed, maintained and operated in accordance with the instructions provided.

Pinnacle Products International, Inc. requires reasonable proof of your date of purchase from an authorized retailer or distributor. Therefore, you should keep your sales slip, invoice, or cancelled check from the original purchase. This Limited Warranty shall be limited to the repair or replacement of parts, which prove defective under normal use and service within the warranty period, and which **Pinnacle Products International, Inc.** shall determine at its reasonable discretion.

This warranty does not apply to products purchased for rental use.

This Limited Warranty does not cover any failures or operating difficulties due to normal wear and tear, accident, abuse, misuse, alteration, misapplication, improper installation or improper maintenance and service by you or any third party. Failure to perform normal and routine maintenance on the heater, shipping damage, damage related to insects, birds, or animals of any kind, and damage due to weather conditions are also not covered. In addition, the Limited Warranty does not cover damage to the finish, such as scratches, dents, discoloration, rust or other weather damage, after purchase.

All transportation costs for the return of the damaged product or parts will be the responsibility of the purchaser. Upon receipt of damaged item, **Pinnacle Products International, Inc.** will examine the item and determine if defective. **Pinnacle Products International, Inc.** will repair or replace and return the item, freight pre-paid. If **Pinnacle Products International, Inc.** finds the item to be in normal operating condition, or not defective, the item will be returned freight collect. This Limited Warranty is in lieu of all other express warranties. **Pinnacle Products International, Inc.** disclaims all warranties for products that are purchased from sellers other than authorized retailers or distributors.

AFTER THE PERIOD OF THE ONE (1) YEAR EXPRESS WARRANTY EXPIRES, **Pinnacle Products International, Inc.** DISCLAIMS ANY AND ALL IMPLIED WARRANTIES, INCLUDING WITHOUT LIMITATION THE IMPLIED WARRANTIES OF MERCHANTABILITY AND FITNESS FOR A PARTICULAR APPLICATION. FURTHER, **Pinnacle Products International, Inc.** SHALL HAVE NO LIABILITY WHATSOEVER TO PURCHASER OR ANY THIRD PARTY FOR ANY SPECIAL, INDIRECT, PUNITIVE, INCIDENTAL, OR CONSEQUENTIAL DAMAGES. **Pinnacle Products International, Inc.** assumes no responsibility for any defects caused by third parties. This Limited Warranty gives the purchaser specific legal rights; a purchaser may have other rights depending upon where he or she lives. Some states do not allow the exclusion or limitation of special, incidental or consequential damages, or limitations on how long a warranty lasts, so the above exclusion and limitations may not apply to you.

Pinnacle Products International, Inc. does not authorize any person or company to assume for it any other obligation or liability in connection with the sale, installation, use, removal, return, or replacement of its equipment, and no such representations are binding on **Pinnacle Products International, Inc.**

Always be sure to specify model number and serial number when making any claim with **Pinnacle Products International, Inc.** For your convenience use the space provided below to list this information:

Keep this warranty

Model #: _____

Serial #: _____

Date of Purchase: _____

(To be filled in by purchaser)